

Presentation on

# CNC MACHINES

By: Ranajit Samantaray,  
Dept. of Mechanical Engg.



WELCOME

# CNC Machines

- **What is a CNC Machine?**
- CNC : Computer Numerical Control
- A machine which is controlled by certain letters , numbers and symbols in form of a program by the help of a computer is known as CNC machine.

## The Evolution of NC

Father of CNC- John T. Parsons (1913–2007)

→1949=>USA Airforce demanded to develop a numerically controlled machine

→1952=> prototype CNC m/c demonstrated.

→1980=>in NC m/c, computer used to link directly controller to machine.

# TYPES OF CNC MACHINE

There are many different types of CNC Machines used in industry, Such as:

- Mills and Machining Centers
- Lathes and Turning Centers
- Drilling Machines
- EDM Sinker and wire cut Machines
- Flame and Laser-Cutting Machines
- Water Jet Profilers

# TYPES OF CNC MACHINE CONTROL UNITS

- ✓ FANUC CONTROLL
- ✓ SIEMENS
- ✓ GSK
- ✓ MECH 3 etc

# PROGRAM INPUT

Different ways of data input are :

- MDI : Manual Data Input
- PROGRAM PREPARATION WITH CAD CAM
- PROGRAM DATA TRANSFER FROM PC TO CNC M/C
- PROGRAM DATA TRANSFER FROM PC TO DNC OPERATIONS

# OPERATIONAL FEATURES of CNC MACHINES

**A CNC control system includes a velocity loop within an axis drive system and a position loop external to the axis drive system.**

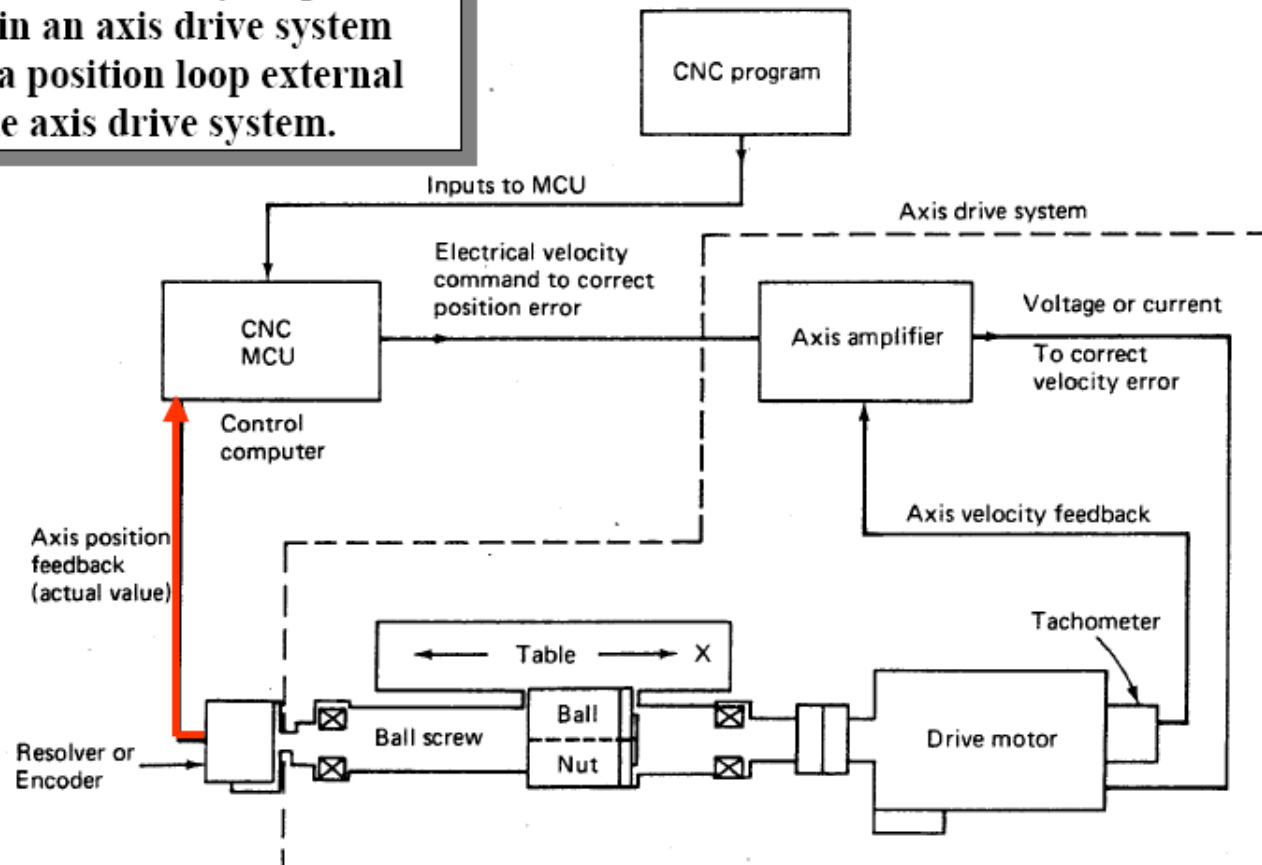

- For a CNC machine control unit (MCU) decides cutting
  - speed, feed, depth of cut, tool selection , coolant on off and tool paths.
  - The MCU issues commands in form of
  - numeric data to motors that position slides and tool accordingly.

# Overview

- A numerical control, or “NC”, system controls many machine functions and movements which were traditionally performed by skilled machinists.
- Numerical control developed out of the need to meet the requirements of high production rates, uniformity and consistent part quality.
- Programmed instructions are converted into output signals which in turn control machine operations such as spindle speeds, tool selection, tool movement, and cutting fluid flow.



**Figure 6.1** Basic components of an NC system.

# Overview

- By integrating a computer processor, computer numerical control, or “CNC” as it is now known, allows part machining programs to be edited and stored in the computer memory as well as permitting diagnostics and quality control functions during the actual machining.
- All CNC machining begins with a part program, which is a sequential instructions or coded commands that direct the specific machine functions.
- The part program may be manually generated or, more commonly, generated by computer aided part programming systems.

# Basic CNC Principles

All computer controlled machines are able to accurately and repeatedly control motion in various directions. Each of these directions of motion is called an axis. Depending on the machine type there are commonly two to five axes.

Additionally, a CNC axis may be either a linear axis in which movement is in a straight line, or a rotary axis with motion following a circular path.

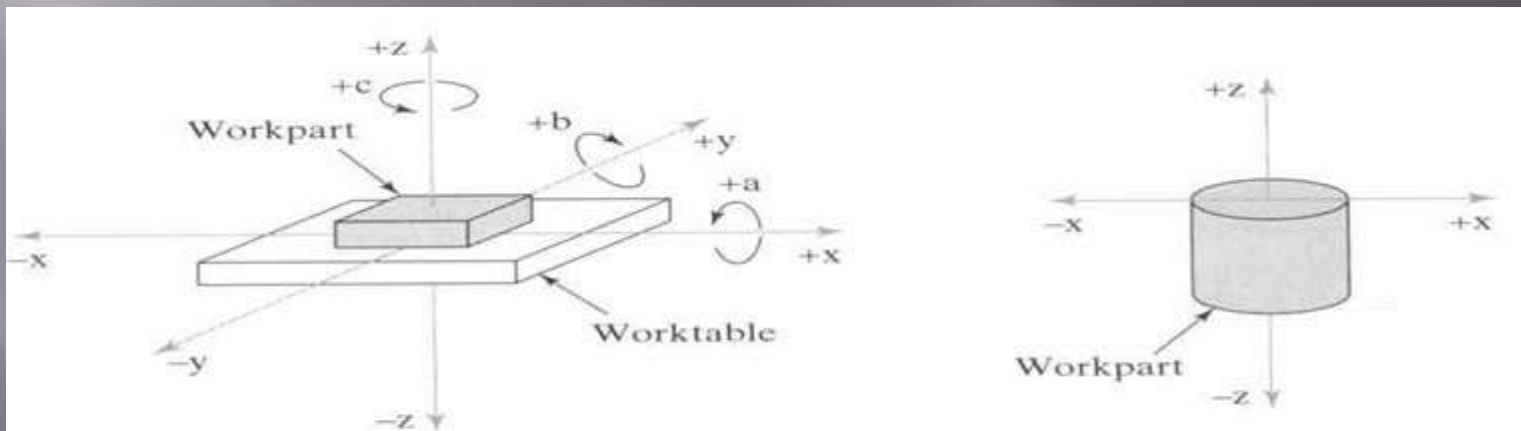
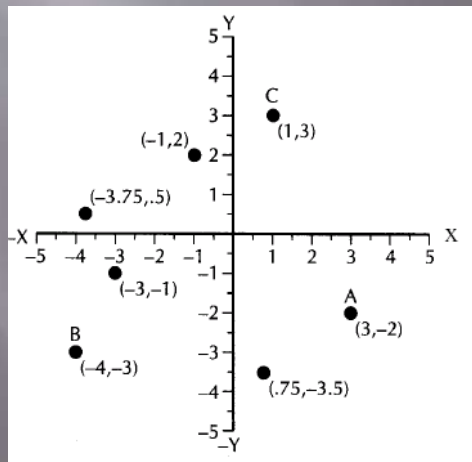
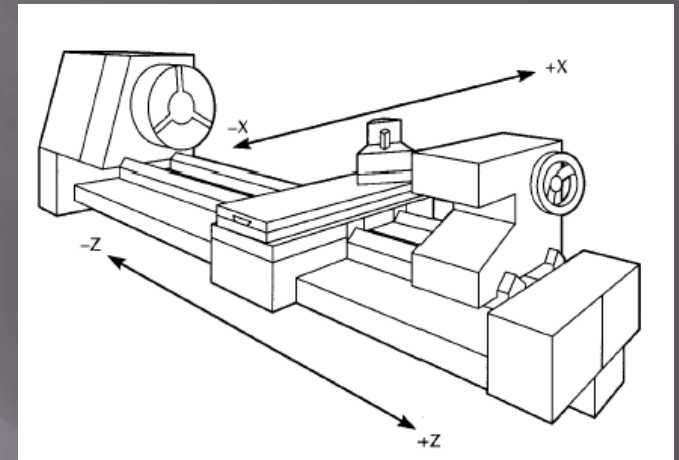
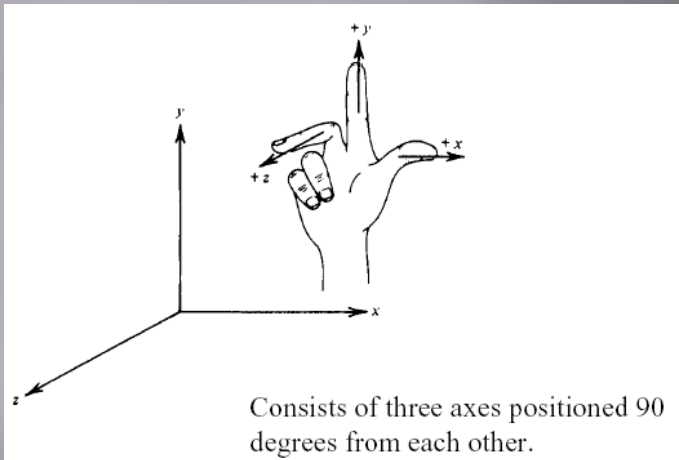

**Figure** Coordinate systems used in NC: (a) for flat and prismatic work and (b) for rotational work. (On most turning machines, the z-axis is horizontal rather than vertical as we have shown it.)

# Motion control - the heart of CNC

- The most basic function of any CNC machine is automatic, precise, and consistent motion control.
- Rather than applying completely mechanical devices to cause motion as is required on most conventional machine tools, CNC machines allow motion control in a revolutionary manner.
- All forms of CNC equipment have two or more directions of motion, called axes. These axes can be precisely and automatically positioned along their lengths of travel.
- The two most common axis types are linear (driven along a straight path) and rotary (driven along a circular path).

# Basic CNC Principles Coordinates System:



Absolute Coordinate System

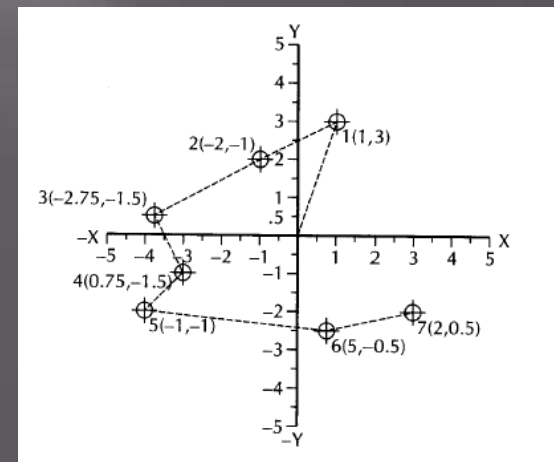

Incremental Coordinate System

## Work Positioning:

- The method of accurate work positioning in relation to the cutting tool is called the “rectangular coordinate system.” On the vertical mill, the horizontal base line is designated the “X” axis, while the vertical base line is designated the “Y” axis. The “Z” axis is at a right angle, perpendicular to both the “X” and “Y” axes.
- Increments for all base lines are specified in linear measurements, for most machines the smallest increment is one ten-thousandth of an inch (.0001). If the machine is graduated in metric the smallest increment is usually one thousandth of a millimeter (.001mm).
- The rectangular coordinate system allows the mathematical plotting of points in space. These points or locations are called “coordinates.” The coordinates in turn relate to the tool center and dictate the “tool path” through the work.

# Basic CNC Principles

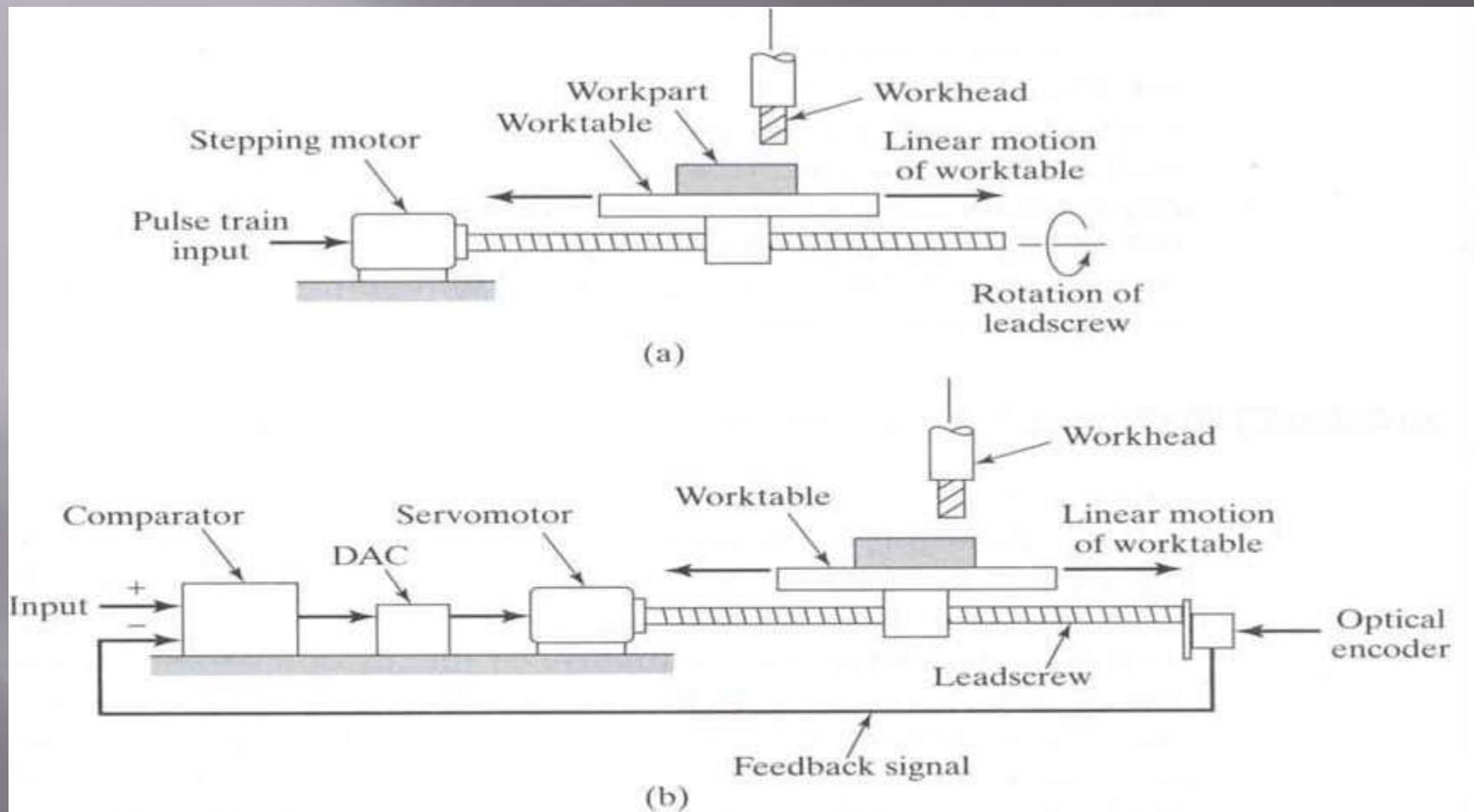

**Figure** Two types of motion control in NC: (a) open loop and (b) closed loop.

# CNC Lathe

Automated version of a manual lathe.

Programmed to change tools automatically.

Used for turning and boring wood, metal and plastic.

## How CNC Lathe Works:

- Controlled by G and M codes.
- These are number values and co-ordinates.
- Each number or code is assigned to a particular operation.
- Typed in manually to CAD/CAM by machine operators.
- G&M codes are automatically generated by the computer software.

# CNC LAHTE



# CNC Machines- Advantages/Disadvantages

## Advantages:

- High Repeatability and Precision e.g. Aircraft parts
- Volume of production is very high
- Complex contours/surfaces need to be machined. etc
- Flexibility in job change, automatic tool settings, less scrap
- More safe, higher productivity, better quality
- Less paper work, faster prototype production, reduction in lead times

## Disadvantages:

- Costly setup, skilled operators
- Computers, programming knowledge required
- Maintenance is difficult

# How CNC Works

- Controlled by G and M codes.
- These are number values and co-ordinates.
- Each number or code is assigned to a particular operation.
- Typed in manually to CAD by machine operators.
- G&M codes are automatically generated by the computer software.

# Features of CNC Lathe

- The tool or material moves.
- Tools can operate in 1-5 axes.
- Larger machines have a machine control unit (MCU) which manages operations.
- Movement is controlled by a motors .
- Feedback is provided by sensors.
- Tool magazines are used to change tools automatically.

# Tools

- Most are made from high speed steel (HSS), tungsten carbide or ceramics.
- Tools are designed to direct waste away from the material.
- Some tools need coolant such as oil to protect the tool and work.

# Tool Paths, Cutting and Plotting Motions

- Tool paths describes the route the cutting tool takes.
- Motion can be described as point to point, straight cutting or contouring.
- Speeds are the rate at which the tool operates e.g. rpm.
- Feeds are the rate at which the cutting tool and work piece move in relation to each other.
- Feeds and speeds are determined by cutting depth, material and quality of finish needed. e.g. harder materials need slower feeds and speeds.
- Roughing cuts remove larger amounts of material than finishing cuts.
- Rapid traversing allows the tool or work piece

# CNC Programming Basics

- CNC instructions are called part program commands.
- When running, a part program is interpreted one command line at a time until all lines are completed.
- Commands, which are also referred to as blocks, are made up of words which each begin with a letter address and end with a numerical value.

# CNC programming

Important things to know:

- Coordinate System
- Units, incremental or absolute positioning
- Coordinates: X,Y,Z,
- Feed rate and spindle speed
- Coolant Control: On/Off, Flood, Mist
- Tool Control: Tool and tool parameters

# CNC programming

Programming consists of a series of instructions in form of letter codes

Preparatory Codes:

- G codes- Initial machining setup and establishing operating conditions
- N codes- specify program line number to executed by the MCU
- Axis Codes: X,Y,Z - Used to specify motion of the slide along X, Y, Z direction
- Feed and Speed Codes: F and S- Specify feed and spindle speed
- Tool codes: T – specify tool number
- Miscellaneous codes – M codes For coolant control and other activities

# Programming Key Letters

- O - Program number (Used for program identification)
- N - Sequence number (Used for line identification)
- G - Preparatory function
- X - X axis designation
- Y - Y axis designation
- Z - Z axis designation
- R - Radius designation
- F - Feed rate designation
- S - Spindle speed designation
- H - Tool length offset designation
- D - Tool radius offset designation
- T - Tool Designation
- M - Miscellaneous function

## Explanation of commonly used G codes

- G00 – Preparatory code to control final position of the tool and not concerned with the path that is followed in arriving at the final destination.
- G01 – Tool is required to move in a straight line connecting current position and final position. Used for tool movement without any machining- point to point control. (linear interpolation)
- G02 – Tool path followed is along an arc specified by I, J and K codes.( circular interpolation)

# Table of Important G codes

## G-CODE

<b>G00</b>	→ Rapid Positioning	<b>G71</b>	→ Rough cutting(Turning)
<b>G01</b>	→ Linear Interpolation	<b>G72</b>	→ Rough cutting(Facing)
<b>G02</b>	→ Circular Interpolation CW	<b>G73</b>	→ Rough cutting(Profile)
<b>G03</b>	→ Circular Interpolation CCW	<b>G74</b>	→ Grooving(Face grooving)
<b>G04</b>	→ Dwell Time	<b>G75</b>	→ Grooving(Surface grooving)
<b>G20</b>	→ Input in INCH	<b>G76</b>	→ Thread cutting cycle
<b>G21</b>	→ Input in MM	<b>G80</b>	→ Canned cycle cancel
<b>G28</b>	→ Return to reference position	<b>G81</b>	→ Drilling cycle
<b>G40</b>	→ Cutter radius compensation cancel	<b>G82</b>	→ Drilling cycle with Dwell
<b>G41</b>	→ Cutter radius compensation left side	<b>G85</b>	→ Reaming cycle
<b>G42</b>	→ Cutter radius compensation right side	<b>G90</b>	→ Absolute mode
<b>G50</b>	→ Scaling OFF	<b>G91</b>	→ Incremental mode
<b>G51</b>	→ Scaling ON	<b>G92</b>	→ Coordinate system setting/ Max spindle speed
<b>G52</b>	→ Datum Shift	<b>G94</b>	→ Feed per minute(mm/min)
<b>G53</b>	→ Machine Coordinate System	<b>G95</b>	→ Feed per revolution(mm/rev)
<b>G68</b>	→ Coordinate system rotation ON	<b>G96</b>	→ Constant cutting speed(m/min)
<b>G69</b>	→ Coordinate system rotation OFF	<b>G97</b>	→ Constant rotational speed / Revolution per minute(RPM)
<b>G70</b>	→ Finishing cycle		

# Table of Important M codes

- M00 Program stop
- M01 Optional program stop
- M02 Program end
- M03 Spindle on clockwise
- M04 Spindle on counterclockwise
- M05 Spindle stop
- M06 Tool change
- M08 Coolant on
- M09 Coolant off
- M10 Clamps on
- M11 Clamps off
- M30 Program stop, reset to start

# Program Command Parameters

Optimum machine programming requires consideration of certain machine operating parameters including:

- Positioning control
- Compensations
- Special machine features

Positioning control is the ability to program tool and machine slide movement simultaneously along two or more axes. Positioning may be for point-to-point movement or for contouring movement along a continuous path. Contouring requires tool movement along multiple axes simultaneously. This movement is referred to as "Interpolation" which is the process of calculating intermediate values between specific points along a programmed path and outputting those values as a precise motion. Interpolation may be linear having just a start and end point along a straight line, or circular which requires an end point, a center and a direction around the arc.

# CAD/CAM

Two computer-based systems which impact the use of CNC technology are CAD (computer aided design) and CAM (computer aided manufacturing). A computer aided design, or CAD, system uses computers to graphically create product designs and models. These designs can be reviewed, revised, and refined for optimum end use and application. Once finalized, the CAD design is then exported to a computer aided manufacturing, or CAM, system.

CAM systems assist in all phases of manufacturing a product, including process planning, production planning, machining, scheduling, management and quality control.

# Programming Example

## *Cylindrical Part*

Raw Material

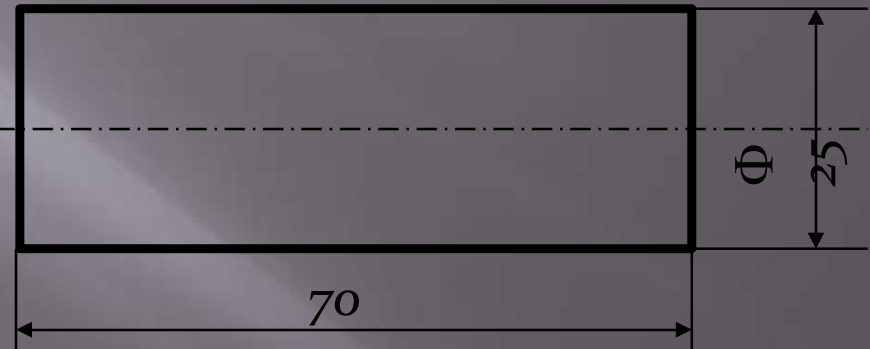

Finished Part

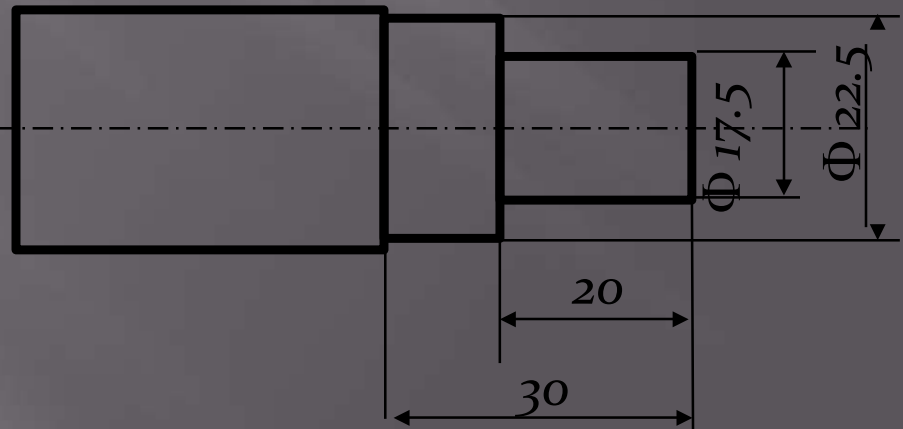

# Programming Example (Cylindrical Part)

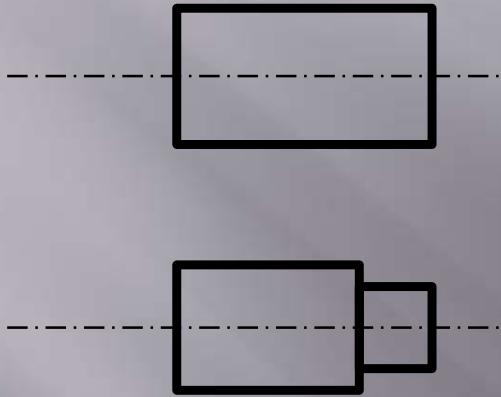

O0077

```
N0005 G28 U0.0 W0.0;  
N0010 T0202;  
N0020 G97 S1500 M03;  
N0030 G00 X50.0 Z1.0 ;  
N0040 G71 U1.0 R2.0;  
N0050 G71 P0060 Q00 U0.5 W0.2 F0.2;  
N0060 G01 X13.0;  
N0070 X15.0 Z-1.0;  
N0080 Z-30.0  
N0090 X23.0  
N0100 X25.0 Z-50.0;  
N0110 X50.0;  
N0120 G70 P0060 Q0110 S2500 F0.1;  
N0130 G28 U0.0 W0.0,  
N0140 M30
```

Thank You  
Any Questions 😊



